

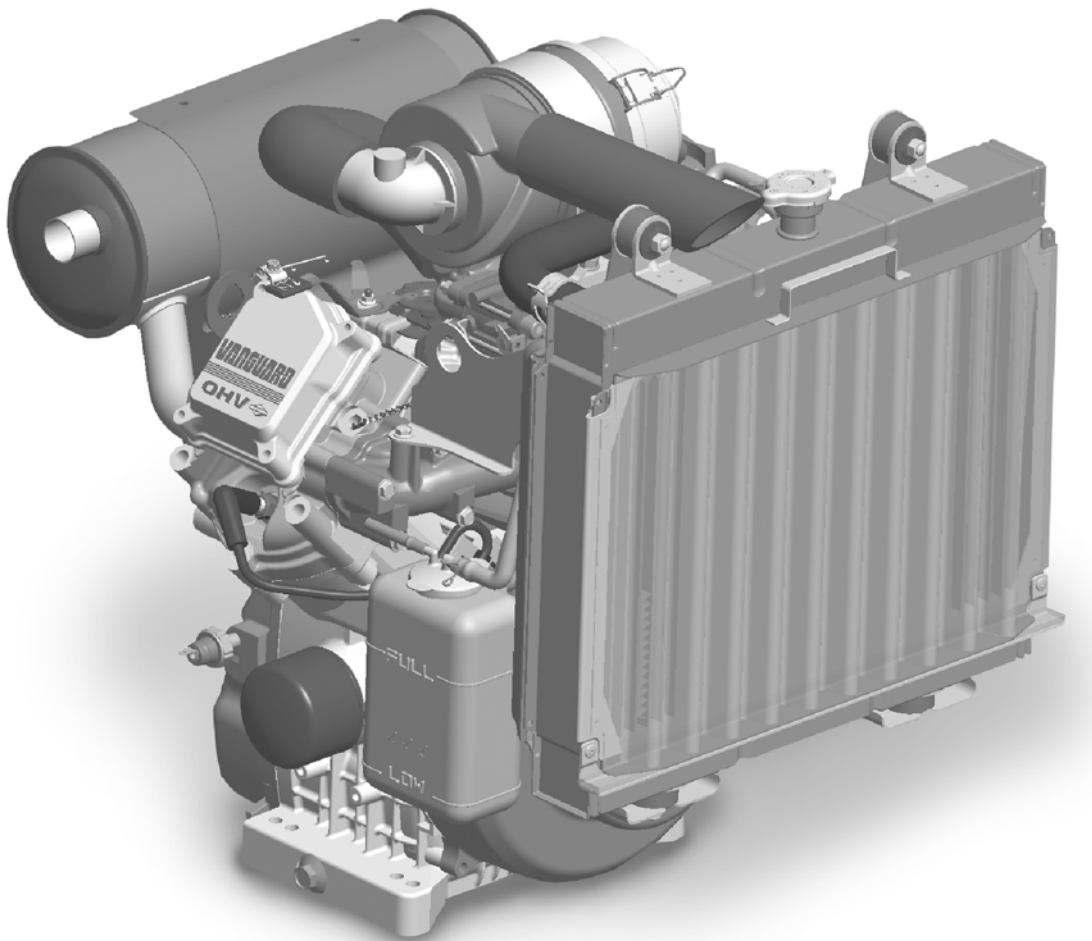

Operating & Maintenance Instructions

The Power That Works For You.™



Model 470000, 610000 Series covered in this manual

www.briggsandstratton.com

Safety References

The safety alert symbol  is used to identify safety information about hazards that can result in personal injury. A signal word (DANGER, WARNING, or CAUTION) is used with the alert symbol to indicate the likelihood and the potential severity of injury. In addition, a hazard symbol may be used to represent the type of hazard.

 **DANGER** indicates a hazard which, if not avoided, **will result in death or serious injury.**

 **WARNING** indicates a hazard which, if not avoided, **could result in death or serious injury.**

 **CAUTION** indicates a hazard which, if not avoided, **might result in minor or moderate injury.**

CAUTION, when used **without** the alert symbol, indicates a situation that **could result in damage to the engine.**





















  This manual contains safety information to make you aware of the hazards and risks associated with engines, and how to avoid them. Because Briggs & Stratton does not necessarily know what equipment this engine will power, it is important that you read and understand these instructions and the instructions for the equipment this engine powers.

Table of Contents

Safety References	2
Engine Features	3
Starting Engine and Safety	4
Operating Engine	5
Stopping Engine	5
Troubleshooting	6
Oil	7
Fuel	9
Coolant	10
Specifications/Emission Information	11
Engine Maintenance	12
Storage	16
Service / Parts	17
Warranty Information / Emission	18

SYMBOLS ASSOCIATED WITH THIS ENGINE:

	Fire		Read Manual
	Explosion		Oil
	Kickback		Fuel
	Hot Surface		Hot Liquid or Steam
	Toxic Fumes		Fuel Shutoff
	Moving Parts		On Off
	Shock		Run
	Stop		Choke
	Slow		Fast

WARNING

Briggs & Stratton does not approve or authorize the use of these engines on 3-wheel All Terrain Vehicles (ATVs), motor bikes, fun/recreational go-karts, aircraft products or vehicles intended for use in competitive events. Use of these engines in such applications could result in property damage, serious injury (including paralysis), or even death.

WARNING

The engine exhaust from this product contains chemicals known to the State of California to cause cancer, birth defects, or other reproductive harm.

CAUTION

This engine is shipped from Briggs & Stratton without oil. If you start the engine without oil, the engine will be damaged beyond repair and will not be covered under warranty.

Engine Features

1. Oil Pressure Sensor
2. Spark Plug (2 locations)
3. Choke Control
4. Muffler
5. Throttle Control (2 possible locations)
6. Fuel Pump (Model 470000 equipped with 1; Model 610000 equipped with 2)
7. Air Cleaner
8. Radiator and Radiator Cap
9. Radiator Screen and Handle
10. Fuel Filter
11. Oil Fill Cap
12. Dipstick
13. Oil Drain Plug (2 locations)
14. Starter
15. Starter Solenoid
16. Fan Belt
17. Radiator Drain Plug
18. Radiator Reservoir
19. Oil Filter
20. Engine Model Label
Model - Type - Code

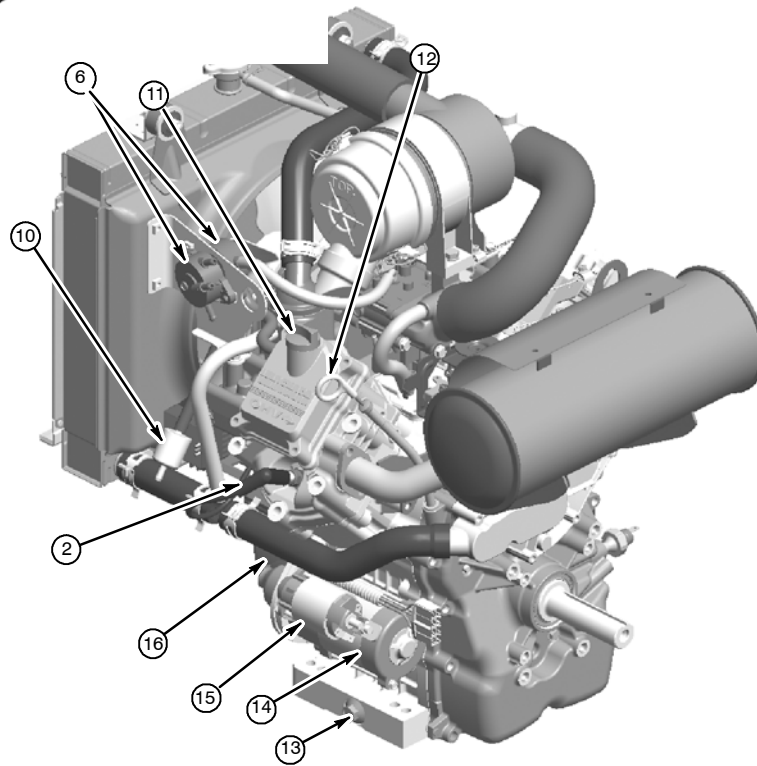
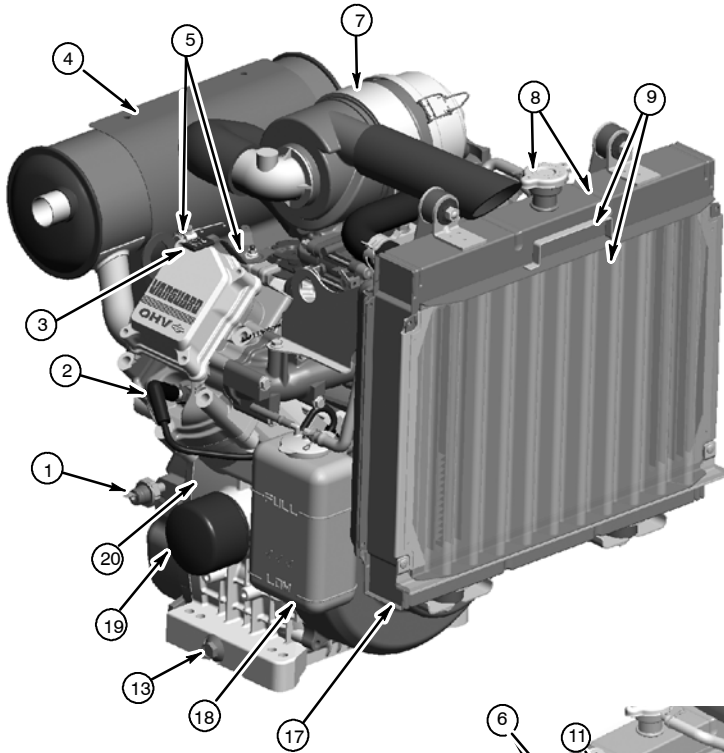

Before Starting Engine

1. This engine is shipped without coolant and oil. Follow the instructions on adding coolant (page 10) and oil (page 7) before starting or running engine.

Starting Engine

2. Open fuel shut-off valve (if equipped).

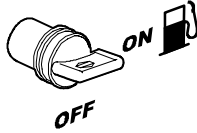

3. Move choke control to CHOKE or START.

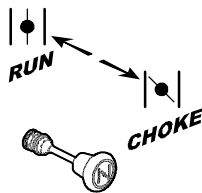

4. Move throttle (if equipped) to FAST.

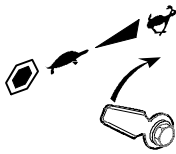

5. Push rocker switch (if equipped) to ON or RUN.



6. Insert key and turn to START. Release key when engine starts.

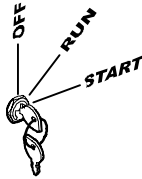

7. Let engine warm up before using equipment.

Note: If choke equipped, slowly adjust toward RUN position. Wait until engine runs smoothly before each choke adjustment.

Safety - When Starting Engine

CAUTION

If you start the engine without oil and/or coolant, the engine may be damaged beyond repair and will not be covered under warranty.

WARNING



- DO NOT crank engine with spark plug removed.
- DO NOT start engine if there is a natural or LP gas leak in area.
- Make sure spark plug, muffler, fuel cap and housings are in place and firmly secured by equipped fasteners.
- Do not use pressurized starting fluids because vapors are flammable.

WARNING



Broken bones, fractures, bruises or sprains could result.

Rapid retraction of starter cord (kickback) will pull hand and arm toward engine faster than you can let go.



- Place equipment on flat level surface.
- Remove all external equipment/engine loads before starting engine.
- Direct coupled equipment components such as, but not limited to, blades, impellers, pulleys, sprockets, etc., must be securely attached.



CAUTION



To prolong starter life, use short starting cycles (5 seconds maximum, then wait one minute). Follow equipment manufacturer's recommendations for charging battery.



Operating Engine

- Operate equipment with guards in place.
- Keep hands and feet away from rotating parts.
- Tie up long hair and remove jewelry.
- Do not wear loose-fitting clothing, dangling drawstrings or items that could become caught.

 WARNING	
	<p>Running engines produce heat. Engine parts, especially muffler, become extremely hot.</p> <p>Severe thermal burns can occur on contact.</p>
	<p>Combustible debris, such as leaves, grass, brush, etc. can catch fire.</p>
<ul style="list-style-type: none"> • Allow muffler, engine cylinder and fins to cool before touching. • Remove accumulated combustibles from muffler area and cylinder area. • Install and maintain in working order a spark arrester before using equipment on forest-covered, grass-covered, brush-covered unimproved land. The state of California requires this (Section 4442 of the California Public Resources Code). Other states may have similar laws. Federal laws apply on federal land. 	

 WARNING	
	<p>Rotating parts can contact or entangle hands, feet, hair, clothing, or accessories.</p> <p>Traumatic amputation or severe laceration can result.</p>
	<p>Rapid retraction of starter cord (kickback) will pull hand and arm toward engine faster than you can let go.</p> <p>Broken bones, fractures, bruises or sprains could result.</p>

 WARNING	
	<p>Engines give off carbon monoxide, an odorless, colorless, poison gas.</p> <p>Breathing carbon monoxide can cause nausea, fainting or death.</p>

 WARNING	
	<ul style="list-style-type: none"> • The manufacturer of equipment on which this engine is installed specifies top speed at which engine will be operated. DO NOT EXCEED this speed.

Stopping Engine

1. Move throttle to SLOW (if equipped).

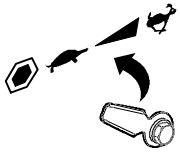

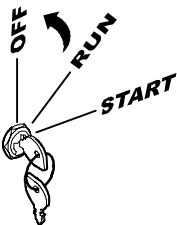

2. Turn key to OFF. Remove key and store out of reach of children.

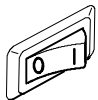

3. Push rocker switch (if equipped) to OFF or STOP.



4. Close fuel shut-off valve (if equipped).

 WARNING	
	<ul style="list-style-type: none"> • Do not stop engine by moving choke control to CHOKE. Backfire, fire or engine damage could occur.

Troubleshooting

Engine Will Not Start

Out of Fuel

- Add fuel to tank.
- Prime engine.
- Open shut-off valve

Engine Flooded

- Set choke (if equipped) to OPEN/RUN position, throttle to FAST and crank engine.

Spark Plug Fouling

- Check to ensure the spark plug is clean. Check the gap with a wire gage and reset to .51 mm or .020 in. if necessary.
- Replace the spark plug if the electrode is burned or worn.

CAUTION

DO NOT OVERFILL. Overfilling may cause smoking, hard starting, spark plug fouling or oil saturation of air filter.



WARNING



- Ensure fuel cap is in place before starting engine
- Turn engine OFF and let engine cool at least 2 minutes before removing fuel cap.
- Check fuel lines, tank, cap, and fittings frequently for cracks or leaks. Replace if necessary.
- Do not crank engine with spark plug removed.

Engine is Smoking or Running Rough

Engine may have been tipped during transport.

- Check for fouled spark plug.
- Check air cleaner filter. If filter is dirty see the *Maintenance* section of this manual

CAUTION

If engine is tipped to transport equipment, to remove debris, to drain oil, etc., **keep the spark plug side of engine up.**



Need assistance? 1-800-233-3723

(USA and Canada ONLY, Pre-recorded message.)

www.briggsandstratton.com

Oil

Capacity

The engine holds approximately 2.5 quarts (2.4 liters).

Oil Recommendation

- Use a high quality detergent oil classified “For Service SG, SH, SJ, SL” or higher, such as Briggs & Stratton 30, Part Number 100005 (20 oz) or 100028 (48 oz).
- Do not use special additives.
- Do not mix gasoline with oil.
- Choose a viscosity according to the table.

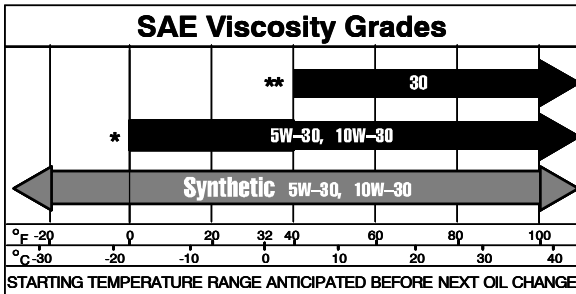

Note: Synthetic oil meeting ILSAC GF-2, API certification mark and API service symbol (shown at left) with “SJ/CF ENERGY CONSERVING” or higher, is an acceptable oil at all temperatures. **Use of synthetic oil does not alter required oil change intervals.**

CAUTION

- * Use of SAE 30 oil below 40° F (4° C) will result in hard starting and possible engine damage due to inadequate lubrication.

CAUTION

- ** The use of non-synthetic multi-viscosity oils (5W-30, 10W-30, etc.) in temperatures above 40° F (4° C) will result in higher than normal oil consumption. When using a multi-viscosity oil, check oil level more frequently.

Checking Oil Level

- Check oil level before starting the engine.
- Keep oil level at FULL. Do not overfill.
- Check level daily, or after every eight (8) hours.

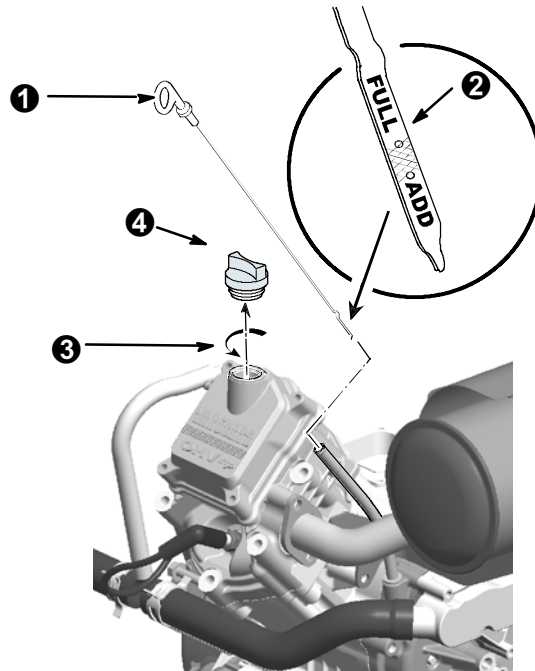

1. Place engine level. Clean around oil fill ③ and oil fill cap ④.
2. Remove dipstick ① and wipe clean with cloth.
3. Push dipstick back in and remove to check oil level. Oil level should be at FULL mark ② on dipstick.
4. If oil is needed, add it slowly.
5. Fill to FULL mark ② on dipstick - recheck.
6. Replace oil fill cap and dipstick firmly.

Adding Oil to New Engine or After Filter Change

1. First add 2 quarts (2 liters).
2. Start and run engine at idle for 30 seconds. See *Starting Instructions*.
3. Shut engine off and wait 30 seconds.
4. Add more oil slowly to bring level to FULL mark on dipstick.
5. Replace oil cap and dipstick.

Changing Oil and Oil Filter

Change oil after first 5 to 8 hours of use, then every 50 hours. Change oil every 25 hours when operating the engine under heavy load or in high temperatures.

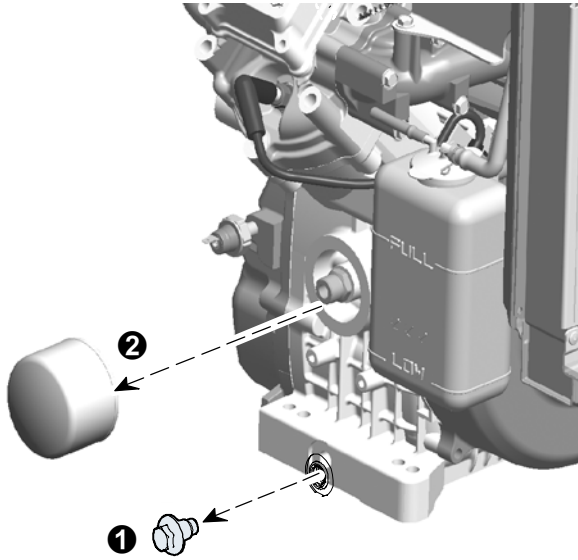

1. With engine OFF but still warm, remove oil drain plug ① and drain oil into appropriate receptacle. Reinstall drain plug.
2. Remove oil filter ②. Before installing new filter, lightly oil filter gasket with fresh, clean oil.
3. Screw filter on by hand until gasket contacts oil filter adapter. Tighten 1/2 to 3/4 turn more.
4. Place engine level and follow *Adding Oil Instructions* (page 7) to add fresh oil.
5. Replace oil fill cap and dipstick.

Oil Pressure

If oil pressure is low, an oil pressure switch (if equipped) will either activate a warning device or stop the engine. Check oil level with dipstick.

- If oil level is between ADD and FULL mark on dipstick **do not try to restart engine**. Contact an Authorized Briggs & Stratton Service Dealer. **Do not operate engine until oil pressure is corrected.**
- If oil level is below ADD mark on dipstick, add oil to bring level to FULL mark. Restart engine and check oil pressure. If pressure is normal, continue to operate engine.

Note: Oil pressure gage (if equipped) is supplied by manufacturer of equipment.

CAUTION

Used oil is a hazardous waste product. Dispose of used oil properly. Do not discard with household waste. Check with your local authorities, service center, or dealer for safe disposal/recycling facilities.

Fuel

Type of Fuel to Use



- Use clean, fresh, regular unleaded gasoline with a minimum of 85 octane. Fresh fuel prevents gum from forming in the fuel system or on essential carburetor parts. Purchase fuel in quantity that can be used within 30 days.
- For engine protection use Briggs & Stratton Gasoline Additive available from your Authorized Briggs & Stratton Dealer.
- Do not use gasoline which contains Methanol.
- Do not mix oil with gasoline.
- This engine is certified to operate on gasoline. Exhaust Emission Control System: EM (Engine Modifications).

Adding Fuel

1. Remove cap. Fill tank to approximately 1-1/2 inches below top of neck to allow for fuel expansion. Be careful not to overfill.
2. Replace cap before starting.

CAUTION
Some fuels, called oxygenated or reformulated fuels, are fuels blended with alcohols or ethers. Excessive amounts of these blends can damage the fuel system or cause performance problems. If any undesirable operating symptoms occur, use gasoline with a lower percentage of alcohol or ether.

 WARNING
  Starting engine creates sparking. Fuel vapors are extremely flammable and explosive. Fire or explosion can cause severe burns or death.
<ul style="list-style-type: none">• Do not use pressurized starting fluids• Fuel equipment outdoors, away from open flames, sparks and other ignition sources, such as appliances with pilot lights.• Store fuel away from ignition sources.

 WARNING
 
<ul style="list-style-type: none">• Turn engine OFF and let engine cool at least 2 minutes before removing fuel cap.• Fill fuel tank outdoors or in well-ventilated area.• Do not overfill fuel tank. Fill tank to approximately 1-1/2 inches below top of neck to allow for fuel expansion.• If fuel spills, wait until it evaporates before starting engine.• Keep gasoline away from sparks, open flames, pilot lights, heat, and other ignition sources.• Check fuel lines, tank, cap, and fittings frequently for cracks or leaks. Replace if necessary.

Coolant

- A 50/50 mixture is required of phosphate-free antifreeze and tap water for heat dissipation, rust resistance and lubrication.
- Normal reading on coolant temperature gauge (if equipped) should be 175° to 195°F (80° to 90°C) when engine is running.
- If coolant temperature rises above 220° F (105° C), the temperature light (if equipped) will illuminate. Idle engine down for a while. Then stop engine. Once engine is cooled, check coolant level, fan belt tension and clean any clogged radiator fins.

Adding Coolant

1. Fill radiator to bottom of filler neck and fill reservoir between FULL and LOW ❶. Replace radiator cap.

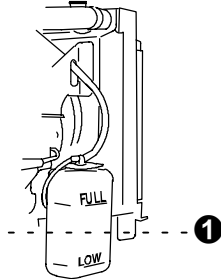

2. Start and run engine for 30 seconds. See *Starting Instructions*.
3. Shut engine off to allow it to cool. Recheck coolant levels in radiator and reservoir.

Changing Coolant

Coolant should be replaced every year, unless an approved extended life coolant is used. Then replace every 3000 hours.

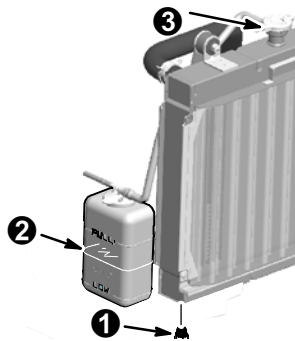

1. Remove drain plug ❶. As coolant is running out, open radiator cap ❷ to allow any trapped coolant to drain. Replace drain plug.
2. Remove reservoir bottle ❸, drain it and reinstall.
3. Fill radiator to bottom of filler neck and reservoir bottle between FULL and LOW. Replace radiator cap.
4. Start and run engine for 30 seconds.
5. Shut engine off and allow it to cool. Recheck coolant levels in radiator and reservoir.

WARNING



- Do not touch radiator or open radiator cap, or open radiator reservoir when engine is hot or running.
- Allow engine to cool before changing or adding coolant.

WARNING



Never remove radiator cap or radiator reservoir cap while the engine is hot or running. Severe thermal burns or injury can occur by escaping steam or hot engine coolant.

- Stop engine and allow to cool before removing radiator or reservoir cap.
- To remove reservoir cap after engine is cool, place a thick cloth over the cap and remove it slowly.
- To remove radiator cap after engine is cool, place a thick cloth over cap and rotate it slowly counter-clockwise to the first stop. Pressurized steam may emit from the cap, stand back to avoid injury. Once all pressure is released, rotate cap counter-clockwise while pushing down on cap to remove.

CAUTION

Used coolant is a hazardous waste product. Dispose of used coolant properly. Do not discard with household waste. Check with your local authorities, service center, or dealer for safe disposal/recycling facilities.

Engine Specifications

We recommend that you contact an authorized Briggs & Stratton Service Dealer for all maintenance and service of the engine and engine parts. Use only genuine Briggs & Stratton parts.

In the state of California, Model Series 470000 engines are certified by the California Air Resources Board to meet emissions standards for 250 hours. Model 610000 engines are certified for 1000 hours. Such certification does not grant the purchaser, owner or operator of this engine any additional warranties with respect to the performance or operational life of this engine. This engine is warranted solely according to the product and emissions warranties stated elsewhere in this manual.

Model Series 470000

Bore 3.19 in. (81 mm)
 Stroke 2.87 in. (73 mm)
 Displacement 45.9 cu. in. (752 cc)

Model Series 610000

Bore 3.36 in. (85.5 mm)
 Stroke 3.40 in. (86.5 mm)
 Displacement 60.6 cu. in. (993 cc)

Tune up Specifications

Armature air gap .. 0.005 - 0.007 in. (0.13 - 0.18 mm)
 Spark plug gap 0.020 in. (0.51 mm)
 Valve clearance with valve springs installed and piston 1/4 in. (6 mm) past top dead center (check when engine is cold).
 Intake 0.007 - 0.010 in. (0.18 - 0.25 mm)
 Exhaust 0.007 - 0.010 in. (0.18 - 0.25 mm)

Note: For practical operation, the horsepower loading should not exceed 85% of rated horsepower. Engine power will decrease 3-1/2% for each 1,000 feet (300 meters) above sea level and 1% for each 10° F (5.6° C) above 77° F (25° C). It will operate satisfactorily at an angle up to 25°.

Model, Type and Code Number

To get replacement parts or technical assistance in the future write your engine Model, Type and Code number along with the date of purchase here. These numbers are located on your engine, see **Engine Features** (page 3).

Model Series

--	--	--	--	--	--	--

Type

--	--	--	--	--	--	--

Code

--	--	--	--	--	--	--	--	--	--

Month/Day/Year

--	--	--	--	--	--	--

Technical Information

Power Ratings: The power ratings for an individual engine model are initially developed by starting with SAE (Society of Automotive Engineers) code J1940 (Small Engine Power & Torque Rating Procedure) (Revision 2002-05). Given both the wide array of products on which our engines are placed, and the variety of environmental issues applicable to operating the equipment, it may be that the engine you have purchased will not develop the rated horsepower when used in a piece of power equipment (actual "on-site" power). This difference is due to a variety of factors including, but not limited to, the following: differences in altitude, temperature, barometric pressure, humidity, fuel, engine lubrication, maximum governed engine speed, individual engine to engine variability, design of the particular piece of power equipment, the manner in which the engine is operated, engine run-in to reduce friction and clean out of combustion chambers, adjustments to the valves and carburetor, and other factors. The power ratings may also be adjusted based on comparisons to other similar engines utilized in similar applications, and will therefore not necessarily match the values derived using the foregoing codes.

Emission Information

Engines that are certified to meet the California Air Resources Board (CARB) Tier 2 Emission Standards must display information regarding the Emissions Durability Period and the Air Index. Briggs & Stratton makes this information available to the consumer on our emission labels. The engine emission label will indicate certification information.

The **Emissions Durability Period** describes the number of hours of actual running time for which the engine is certified to be emissions compliant, assuming proper maintenance in accordance with the Operating & Maintenance Instructions. The following categories are used:

Moderate:

Engine is certified to be emission compliant for 125 hours of actual engine running time.

Intermediate:

Engine is certified to be emission compliant for 250 hours of actual engine running time.

Extended:

Engine is certified to be emission compliant for 500 hours of actual engine running time. For example, a typical walk-behind lawn mower is used 20 to 25 hours per year. Therefore, the **Emissions Durability Period** of an engine with an **intermediate** rating would equate to 10 to 12 years.

Certain Briggs & Stratton engines will be certified to meet the United States Environmental Protection Agency (USEPA) Phase 2 emission standards. For Phase 2 certified engines, the Emissions Compliance Period referred to on the Emissions Compliance label indicates the number of operating hours for which the engine has been shown to meet Federal emission requirements.

For engines less than 225 cc displacement.

Category C = 125 hours

Category B = 250 hours

Category A = 500 hours

For engines of 225 cc or more displacement.

Category C = 250 hours

Category B = 500 hours

Category A = 1000 hours.

Engine Maintenance

Regular maintenance will improve the performance and extend the life of the engine. Contact any Authorized Briggs & Stratton Dealer for service. **Use only genuine Briggs & Stratton parts. Other parts may not perform as well, may damage the engine, and may result in injury.** In addition, use of other parts may void your warranty.

Follow the instructions and schedule below.

Task <i>Perform task at hourly or calendar interval, whichever comes first.</i>	Every 8 Hours or Daily	50 Hours	100 Hours	250 Hours	400 Hours	Yearly	1200 Hours
Check oil level	Every 8 Hours or Daily						
Clean radiator	Every 8 Hours or Daily						
Check coolant level	Every 8 Hours or Daily						
Clean spark arrestor (if equipped)	Every 8 Hours or Daily						
Change oil and oil filter **		50 Hours	100 Hours				
Clean air filter cartridge*		50 Hours	100 Hours				
Check fan belt		50 Hours	100 Hours				
Check valve clearance		50 Hours	100 Hours	250 Hours			
Check battery electrolyte		50 Hours	100 Hours	250 Hours			
Replace air filter cartridge*		50 Hours	100 Hours	250 Hours	400 Hours		
Change fuel filter		50 Hours	100 Hours	250 Hours	400 Hours		
Change spark plugs		50 Hours	100 Hours	250 Hours	400 Hours	Yearly	
Change coolant ***		50 Hours	100 Hours	250 Hours	400 Hours	Yearly	
Replace safety air filter cartridge (if equipped)*		50 Hours	100 Hours	250 Hours	400 Hours	Yearly	1200 Hours

* Clean more often under dusty conditions or when airborne debris is present. Replace air filter, if very dirty.

** **Change oil after first 5 to 8 hours of use**, then every 50 hours. Change oil every 25 hours when operating the engine under heavy load or in high temperatures. **Check valve clearance after first 50 hours of use**, then every 250 hours.

*** If an extended life coolant is used, interval may be increased to once every 3000 hours.

Emission Control

Maintenance, replacement or repair of the emission control devices and systems may be performed by any nonroad engine repair establishment or individual. However, to obtain “no charge” repairs under the terms and provisions of the Briggs & Stratton warranty statement, any service or emission control part repair or replacement must be performed by a factory authorized dealer.

WARNING



Unintentional sparking can result in fire or electric shock.



Fire or explosion can cause severe burns or death.



Unintentional start-up can result in entanglement, traumatic amputation, or laceration.

Before performing maintenance or repairs:

- Disconnect spark plug wire and keep it away from spark plug.
- Disconnect battery at negative terminal.
- Use only correct tools.
- Do not strike the flywheel with a hammer or hard object because the flywheel may later shatter during operation.
- Do not tamper with governor spring, links or other parts to increase engine speed.

When testing for spark:

- Use approved spark plug tester.
- Do not check for spark with spark plug removed.

CAUTION

Operation of this engine is for the application it was intended for. All the components used to build this engine assembly must remain in place for the proper operation of this engine.

Air Cleaner

Clean air filter cartridge every 100 hrs. To clean cartridge, gently tap on end with handle of screwdriver. Replace cartridge every 400 hours. Clean and replace more often under dusty conditions. Do not remove inner safety cartridge **5** (if equipped), which prevents dirt from entering carburetor when outer cartridge is removed. Replace safety cartridge every 1200 hrs.

1. Unlock clamps **1** and remove cover **2**.
2. Remove cartridge **3** from air cleaner body, **4** and inspect. Replace if very dirty or any damage occurs to cartridge.
3. Carefully clean out cover.
4. Install cartridge in body.
5. Install cover with rubber valve down and lock clamps.

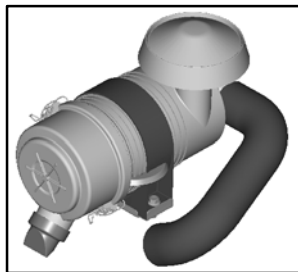

CAUTION

Do not use pressurized air or solvents to clean cartridge. Pressurized air can damage cartridge; solvents will dissolve cartridge.

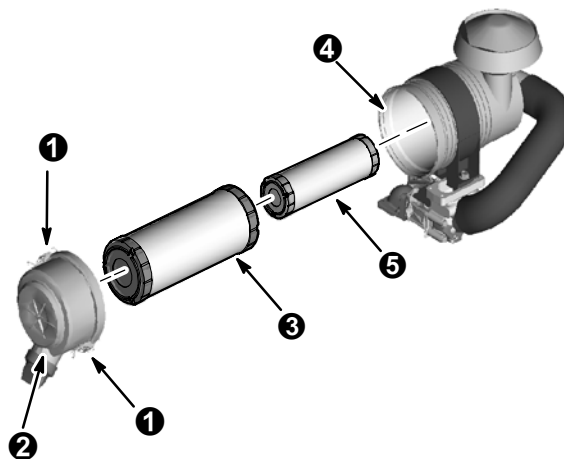

Spark Plug

Check the spark plug every 100 hours. Replace the spark plug if upon inspection the electrode **1** is burned or worn. Ensure the spark plug is clean. Check the gap **2** with a wire gage **3** and reset to .51 mm or 0.020 in. if necessary.

Note: In some areas, local law requires using resistor spark plug to suppress ignition signals. If this engine was originally equipped with resistor spark plug, use same type for replacement.

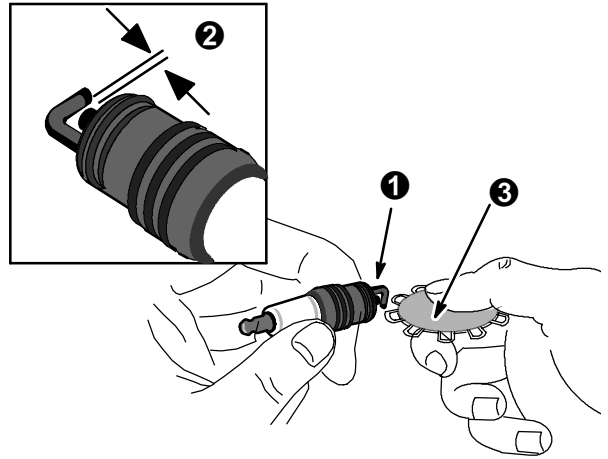

Fan Belt

- Check condition of fan belt for fraying, cracking or cuts.
- Replace if damaged or worn.

To Adjust Fan Belt Tension

1. Loosen bolt **1** and bolt **2**.
2. Fit torque wrench in the square torque hole **3** located on the bracket.
3. Apply 115 in-lbs of torque in direction shown.
4. Hold tension per step 3 and torque bolt **1** and bolt **2** to 135 in-lbs.

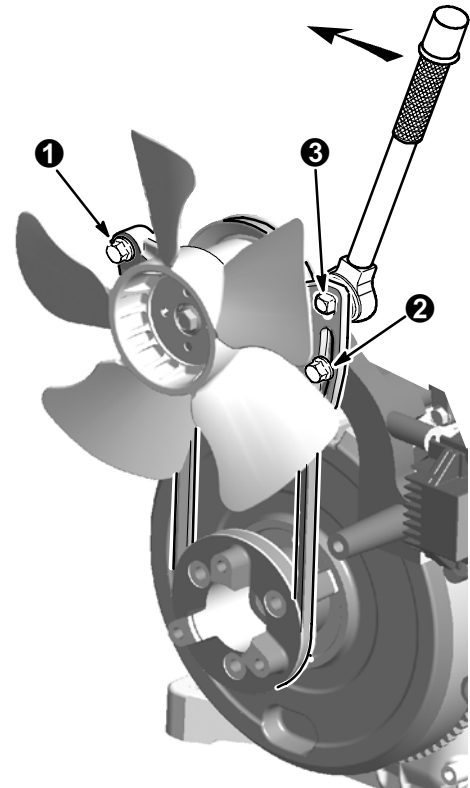

Fuel Filter

Drain fuel tank or close fuel shut-off valve before replacing fuel filter. Otherwise, fuel can leak out creating a fire/explosion hazard.

- When replacing fuel filter, ensure clamps are tight and fuel flows in same direction as FLOW arrow on filter.

WARNING



Replacement parts for fuel system (cap, hoses, tanks, filters, etc.) must be the same as original parts, otherwise fire can occur.

Cleaning Debris

Daily or before every use, clean accumulated debris from engine. Keep linkage, spring and controls clean. Use handle ① on the radiator screen ② to lift off for cleaning. Clean screen thoroughly and clean radiator fins.

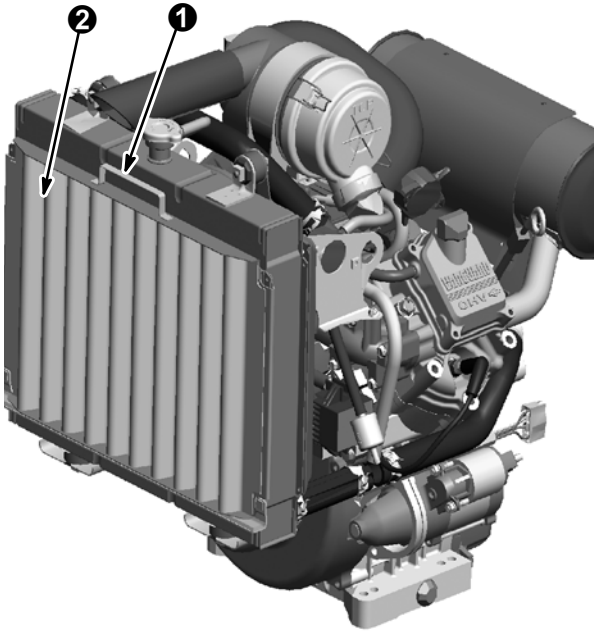

CAUTION

Do not use water to clean engine parts. Water could contaminate fuel system. Low pressure compressed air may be used, be careful not to damage radiator fins.

WARNING



- Engine parts should be kept clean to reduce the risk of overheating and ignition of accumulated debris.

Muffler

WARNING



Replacement parts for the muffler must be the same and installed in the same position as the original parts, otherwise fire can occur.

Valve Clearance

Check valve clearance every 250 hours. Contact an Authorized Briggs & Stratton Service Dealer for this maintenance.



Need assistance? 1-800-233-3723

(USA and Canada ONLY, Pre-recorded message.)

www.briggsandstratton.com

Service

Contact an Authorized Briggs & Stratton Service Dealer. Each one carries a stock of genuine Briggs & Stratton parts and is equipped with special service tools. Trained mechanics assure expert repair service on all Briggs & Stratton engines. Only dealers advertising as "Authorized Briggs & Stratton" are required to meet Briggs & Stratton standards.

When you purchase equipment powered by a Briggs & Stratton engine, you are assured of highly skilled, reliable service at more than 30,000 Authorized Service Dealers worldwide, including more than 5,000 Master Service Technicians. Look for these signs wherever Briggs & Stratton service is offered.

You can find your nearest Authorized Briggs & Stratton Service Dealer through our Dealer Locator on our web site

www.briggsandstratton.com

or in the "Yellow Pages"™ directory under "Engines, Gasoline" or "Gasoline Engines," or "Lawn Mowers" or similar category.



Note: Walking fingers logo and "Yellow Pages" are registered trademarks in various jurisdictions.



Storage

If engine is to be stored over 30 days, prepare as follows:

1. To prevent gum from forming in fuel system or on essential carburetor parts:

If fuel tank contains oxygenated or reformulated gasoline (gasoline blended with an alcohol or an ether) run engine until it stops from lack of fuel.

If fuel tank contains gasoline either run engine until it stops from lack of fuel or add a gasoline additive. If you use a gasoline additive, run the engine for several minutes to circulate through the carburetor. Engine and fuel can be stored up to 24 months with additive.

2. While engine is still warm, change oil.
3. Remove spark plugs and pour about 1 oz (30 ml) of engine oil into each cylinder. Re-install spark plugs and crank engine slowly to distribute oil.
4. Clean engine of surface debris, chaff or grass.

PARTIAL LIST OF GENUINE BRIGGS & STRATTON MAINTENANCE PARTS

<u>PART</u>	<u>PART NO.</u>
Air Cleaner Cartridge (Model 473100)	820263
Air Filter Cartridge (all other Models)	841497
Safety Cartridge, if equipped	821136
Oil	100028
Oil Filter	492932
Fuel Filter (1-1/4 in.) 691035 or (2-1/4 in.) 695666	695666
Fan Belt	807243
Gas Additive	5041
Resistor Spark Plug	692051
Spark Plug Wrench	19374
Spark Tester	19368
Repair Manual	275429

An illustrated shop manual includes common specifications and detailed information covering adjustment, tune-up and repair of Briggs & Stratton liquid-cooled V-Twin OHV engines. It is available for purchase from an Authorized Briggs & Stratton Service Dealer or you can order it from

www.briggsandstratton.com.

WARNING



When storing gasoline or equipment with fuel in the tank:



- Store away from furnaces, stoves, water heaters, or other appliances that have a pilot light or other ignition source because they can ignite gasoline vapors.

When Transporting Equipment:

- Transport with fuel tank EMPTY or with fuel shut-off valve CLOSED.

Warranty Information

Briggs & Stratton Corporation (B&S), the California Air Resources Board (CARB) and the United States Environmental Protection Agency (U.S. EPA) Emission Control System Warranty Statement (Owner's Defect Warranty Rights and Obligations)

The California Air Resources Board (CARB), U.S. EPA and B&S are pleased to explain the Emission Control System Warranty on your small off-road engine (SORE). In California, new small off-road engines model year 2006 and later must be designed, built and equipped to meet the State's stringent anti-smog standards.

Elsewhere in the United States, new non-road, spark-ignition engines certified for model year 1997 and later must meet similar standards set forth by the U.S. EPA. B&S must warrant the emission control system on your engine for the periods of time

listed below, provided there has been no abuse, neglect or improper maintenance of your small off-road engine.

Your emission control system includes parts such as the carburetor, air cleaner, ignition system, fuel line, muffler and catalytic converter. Also included may be connectors and other emission related assemblies.

Where a warrantable condition exists, B&S will repair your small off-road engine at no cost to you including diagnosis, parts and labor.

Briggs & Stratton Emission Control Defects Warranty Coverage

Small off-road engines are warranted relative to emission control parts defects for a period of two years, subject to provisions set forth below. If any covered part on your engine is defective, the part will be repaired or replaced by B&S.

Owner's Warranty Responsibilities

As the small off-road engine owner, you are responsible for the performance of the required maintenance listed in your Operating and Maintenance Instructions. B&S recommends that you retain all your receipts covering maintenance on your small off-road engine, but B&S cannot deny warranty solely for the lack of receipts or for your failure to ensure the performance of all scheduled maintenance.

As the small off-road engine owner, you should however be aware that B&S may deny you warranty coverage if your small off-road engine or a part has failed due to abuse, neglect, improper maintenance or unapproved modifications.

You are responsible for presenting your small off-road engine to an Authorized B&S Service Dealer as soon as a problem exists.

The undisputed warranty repairs should be completed in a reasonable amount of time, not to exceed 30 days.

If you have any questions regarding your warranty rights and responsibilities, you should contact a B&S Service Representative at 1-414-259-5262.

The emission warranty is a defects warranty. Defects are judged on normal engine performance. The warranty is not related to an in-use emission test.

Briggs & Stratton Emission Control Defects Warranty Provisions

The following are specific provisions relative to your Emission Control Defects Warranty Coverage. It is in addition to the B&S engine warranty for non-regulated engines found in the Operating and Maintenance Instructions.

1. Warranted Parts

Coverage under this warranty extends only to the parts listed below (the emission control systems parts) to the extent these parts were present on the engine purchased.

a. Fuel Metering System

- Cold start enrichment system
- Carburetor and internal parts
- Fuel Pump
- Fuel line, fuel line fittings, clamps

b. Air Induction System

- Air cleaner
- Intake manifold

c. Ignition System

- Spark plug(s)
- Magneto ignition system

d. Catalyst System

- Catalytic converter
- Exhaust manifold
- Air injection system, Pulse valve

e. Miscellaneous Items

- Vacuum, temperature, position, time sensitive valves and switches
- Connectors and assemblies

2. Length of Coverage

B&S warrants to the initial owner and each subsequent purchaser that the Warranted Parts shall be free from defects in materials and workmanship which caused the failure of the Warranted Parts for a period of two years from the date the engine is delivered to a retail purchaser.

3. No Charge

Repair or replacement of any Warranted Part will be performed at no charge to the owner, including diagnostic labor which leads to the determination that a Warranted Part is defective, if the diagnostic work is performed at an Authorized B&S Service Dealer. For emissions warranty

service contact your nearest Authorized B&S Service Dealer as listed in the "Yellow Pages" under "Engines, Gasoline," "Gasoline Engines," "Lawn Mowers," or similar category.

4. Claims and Coverage Exclusions

Warranty claims shall be filed in accordance with the provisions of the B&S Engine Warranty Policy. Warranty coverage shall be excluded for failures of Warranted Parts which are not original B&S parts or because of abuse, neglect or improper maintenance as set forth in the B&S Engine Warranty Policy. B&S is not liable to cover failures of Warranted Parts caused by the use of add-on, non-original, or modified parts.

5. Maintenance

Any Warranted Part which is not scheduled for replacement as required maintenance or which is scheduled only for regular inspection to the effect of "repair or replace as necessary" shall be warranted as to defects for the warranty period. Any Warranted Part which is scheduled for replacement as required maintenance shall be warranted as to defects only for the period of time up to the first scheduled replacement for that part. Any replacement part that is equivalent in performance and durability may be used in the performance of any maintenance or repairs. The owner is responsible for the performance of all required maintenance, as defined in the B&S Operating and Maintenance Instructions.

6. Consequential Coverage

Coverage hereunder shall extend to the failure of any engine components caused by the failure of any Warranted Part still under warranty.

BRIGGS & STRATTON ENGINE OWNER WARRANTY POLICY

Effective June 1, 2004 replaces all undated Warranties and all Warranties dated before June 1, 2004

LIMITED WARRANTY

Briggs & Stratton Corporation will repair or replace, free of charge, any part(s) of the engine that is defective in material or workmanship or both. Transportation charges on parts submitted for repair or replacement under this warranty must be borne by purchaser. This warranty is effective for the time periods and subject to the conditions stated below. For warranty service, find the nearest Authorized Service Dealer in our dealer locator map at www.briggsandstratton.com, or by calling 1-800-233-3723, or as listed in the 'Yellow Pages™'.

THERE IS NO OTHER EXPRESS WARRANTY. IMPLIED WARRANTIES, INCLUDING THOSE OF MERCHANTABILITY AND FITNESS FOR A PARTICULAR PURPOSE, ARE LIMITED TO ONE YEAR FROM PURCHASE, OR TO THE EXTENT PERMITTED BY LAW ANY AND ALL IMPLIED WARRANTIES ARE EXCLUDED. LIABILITY FOR INCIDENTAL OR CONSEQUENTIAL DAMAGES ARE EXCLUDED TO THE EXTENT EXCLUSION IS PERMITTED BY LAW. Some states or countries do not allow limitations on how long an implied warranty lasts, and some states or countries do not allow the exclusion or limitation of incidental or consequential damages, so the above limitation and exclusion may not apply to you. This warranty gives you specific legal rights and you may also have other rights which vary from state to state and country to country.

OUR PRODUCT

Vanguard™	ELS™ I/C® Industrial Plus™ Intek™ (Sleeve Bore)	Fource™ Intek™ (Kool Bore) Power Built™ OHV Quantum® Quattro™ Q45™ Sprint™	Classic™	Etek™
------------------	--	---	-----------------	--------------

WARRANTY PERIOD*

Consumer Use	2 years	2 years	2 years	1 year	1 year
Commercial Use		1 year	90 days	90 days	

* **Note the following special warranty periods: 2 years** for Classic™ engines in the European Union and Eastern European countries, for all consumer products in the European Union, and for emission control systems on engines certified by EPA and CARB. **5 years** for consumer use, 90 days for commercial use of Touch-N-Mow® starter on Quantum® and Intek™ engines. **Engines used in competitive racing or on commercial or rental tracks are not warrantied.** Engines operating on Kerosene fuel carry a one year for consumer use, 90 days for commercial use.

The warranty period begins on the date of purchase by the first retail consumer or commercial end user, and continues for the period of time stated in the table above. "Consumer use" means personal residential household use by a retail consumer. "Commercial use" means all other uses, including use for commercial, income producing or rental purposes. Once an engine has experienced commercial use, it shall thereafter be considered as a commercial use engine for purposes of this warranty.

NO WARRANTY REGISTRATION IS NECESSARY TO OBTAIN WARRANTY ON BRIGGS & STRATTON PRODUCTS. SAVE YOUR PROOF OF PURCHASE RECEIPT. IF YOU DO NOT PROVIDE PROOF OF THE INITIAL PURCHASE DATE AT THE TIME WARRANTY SERVICE IS REQUESTED, THE MANUFACTURING DATE OF THE PRODUCT WILL BE USED TO DETERMINE THE WARRANTY PERIOD.

Briggs & Stratton Engines Are Made Under One Or More Of The Following Patents: Design D-247,177 (Other Patents Pending)									
6,691,683	6,472,790	6,239,709	6,040,767	5,765,713	5,503,125	5,197,425	4,977,879	4,453,507	
6,647,942	6,460,502	6,237,555	6,014,808	5,732,555	5,501,203	5,197,422	4,977,877	4,430,984	
6,622,683	6,456,515	6,230,678	6,012,420	5,645,025	5,497,679	5,191,864	4,971,219	D 476,629	
6,615,787	6,382,166	6,213,083	5,992,367	5,642,701	5,320,795	5,188,069	4,895,119	D 457,891	
6,617,725	6,369,532	6,202,616	5,904,124	5,628,352	5,301,643	5,186,142	4,875,448	D 368,187	
6,603,227	6,356,003	6,145,487	5,894,715	5,619,845	5,271,363	5,150,674	4,819,593	D 375,963	
6,595,897	6,349,688	6,142,257	5,887,678	5,606,948	5,269,713	5,138,996	4,720,638	D 309,457	
6,595,176	6,347,614	6,135,426	5,852,951	5,606,851	5,265,700	5,086,890	4,719,682	D 372,871	
6,584,964	6,325,036	6,116,212	5,843,345	5,605,130	5,243,878	5,070,829	4,633,556	D 361,771	
6,557,833	6,311,663	6,105,548	5,823,153	5,497,679	5,235,943	5,058,544	4,630,498	D 356,951	
6,542,074	6,284,123	6,347,614	5,819,513	5,548,955	5,234,038	5,040,644	4,522,080	D 309,457	
6,520,141	6,263,852	6,082,323	5,813,384	5,546,901	5,228,487	5,009,208	4,520,288	D 308,872	
6,495,267	6,260,529	6,077,063	5,809,958	5,445,014	5,197,426	4,996,956	4,512,499	D 308,871	
6,494,175	6,242,828	6,064,027	5,803,035						

ABOUT YOUR ENGINE WARRANTY

Briggs & Stratton welcomes warranty repair and apologizes to you for being inconvenienced. Any Authorized Service Dealer may perform warranty repairs. Most warranty repairs are handled routinely, but sometimes requests for warranty service may not be appropriate. For example, warranty would not apply if engine damage occurred because of misuse, lack of routine maintenance, shipping, handling, warehousing or improper installation. Similarly, warranty is void if the serial number of the engine has been removed or the engine has been altered or modified.

If a customer differs with the decision of the Service Dealer, an investigation will be made to determine whether the warranty applies. Ask the Service Dealer to submit all supporting facts to his Distributor or the Factory for review. If the Distributor or the Factory decides that the claim is justified, the customer will be fully reimbursed for those items that are defective. To avoid misunderstanding which might occur between the customer and the Dealer, listed below are some of the causes of engine failure that the warranty does not cover.

Normal wear:

Engines, like all mechanical devices, need periodic parts service and replacement to perform well. Warranty will not cover repair when normal use has exhausted the life of a part or an engine.

Improper maintenance:

The life of an engine depends upon the conditions under which it operates, and the care it receives. Some applications, such as tillers, pumps and rotary mowers, are very often used in dusty or dirty conditions, which can cause what appears to be premature wear. Such wear, when caused by dirt, dust, spark plug cleaning grit, or other abrasive material that has entered the engine because of improper maintenance, is not covered by warranty.

This warranty covers engine related defective material and/or workmanship only, and not replacement or refund of the equipment to which the engine may be mounted. Nor does the warranty extend to repairs required because of:

1. PROBLEMS CAUSED BY PARTS THAT ARE NOT ORIGINAL BRIGGS & STRATTON PARTS.
2. Equipment controls or installations that prevent starting, cause unsatisfactory engine performance, or shorten engine life. (Contact equipment manufacturer.)
3. Leaking carburetors, clogged fuel pipes, sticking valves, or other damage, caused by using contaminated or stale fuel. (Use clean, fresh, lead-free gasoline and Briggs & Stratton Fuel Stabilizer, Part No. 5041.)

4. Parts which are scored or broken because an engine was operated with insufficient or contaminated lubricating oil, or an incorrect grade of lubricating oil (check oil level daily or after every 8 hours of operation. Refill when necessary and change at recommended intervals.) OIL GARD® may not shut down running engine. Engine damage may occur if oil level is not properly maintained. Read Operating & Maintenance Instructions.
5. Repair or adjustment of associated parts or assemblies such as clutches, transmissions, remote controls, etc., which are not manufactured by Briggs & Stratton.
6. Damage or wear to parts caused by dirt, which entered the engine because of improper air cleaner maintenance, re-assembly, or use of a non-original air cleaner element or cartridge. (At recommended intervals, clean and re-oil the Oil-Foam® element or the foam pre-cleaner, and replace the cartridge.) Read Operating & Maintenance Instructions.
7. Parts damaged by over-speeding, or overheating caused by grass, debris, or dirt, which plugs or clogs the cooling fins, or flywheel area, or damage caused by operating the engine in a confined area without sufficient ventilation. (Clean fins on the cylinder, cylinder head and flywheel at recommended intervals.) Read Operating & Maintenance Instructions.
8. Engine or equipment parts broken by excessive vibration caused by a loose engine mounting, loose cutter blades, unbalanced blades or loose or unbalanced impellers, improper attachment of equipment to engine crankshaft, over-speeding or other abuse in operation.
9. A bent or broken crankshaft, caused by striking a solid object with the cutter blade of a rotary lawn mower, or excessive v-belt tightness.
10. Routine tune-up or adjustment of the engine.
11. Engine or engine component failure, i.e., combustion chamber, valves, valve seats, valve guides, or burned starter motor windings, caused by the use of alternate fuels such as, liquified petroleum, natural gas, altered gasolines, etc.

Warranty is available only through service dealers which have been authorized by Briggs & Stratton Corporation. your nearest Authorized Service Dealer is listed in the "Yellow Pages™" of your telephone directory under "Engines, Gasoline" or "Gasoline Engines," "Lawn Mowers," or similar category.